

Hex Serrated Flange Nut (DIN 6923)

Hexagon Flange Nut | Serrated Locking Face | Bright Zinc Plated | M6 – M20 | Metric Coarse

Direct Channel Hex Serrated Flange Nuts combine a hexagon nut with an integral flange that spreads the clamping load over a wider bearing area, removing the need for a separate washer.

The serrated underside grips the joint face to resist loosening under vibration. Manufactured to DIN 6923 in class 8 steel with a Bright Zinc Plated finish and a 60° metric coarse thread.

SPECIFICATION

Product Type	Hexagon flange nut, serrated
Standard	DIN 6923
Property Class	Steel class 8
Material	Carbon steel
Finish	Bright Zinc Plated (BZP)
Thread	Metric coarse, 60° ISO
Bearing Face	Integral serrated flange (anti-loosening)
Size Range	M6 – M20
Width A/F	10 – 30 mm
Height	6 – 20 mm
Use	Fastening without a separate washer

KEY FEATURES

<ul style="list-style-type: none"> • Conforms to DIN 6923 • Serrated face resists vibration loosening • Bright Zinc Plated (BZP) finish • Metric coarse 60° ISO thread 	<ul style="list-style-type: none"> • Integral flange spreads the clamping load • Removes the need for a separate washer • Class 8 steel • Size range M6 to M20
--	--

TECHNICAL DRAWING

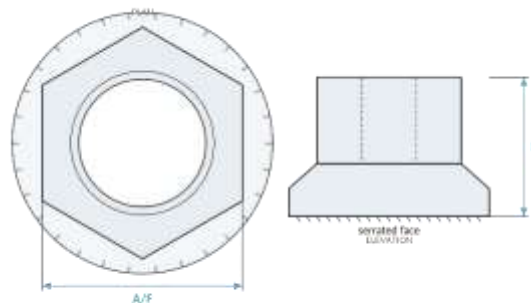

Hex serrated flange nut — plan and elevation, dimensions not to scale

AVAILABLE SIZES

Size	Pitch (mm)	A/F (mm)	Height (mm)	Product Code
M6	1.0	10	6.0	HNF6
M8	1.25	13	8.0	HNF8
M10	1.5	15	10.0	HNF10
M12	1.75	18	12.0	HNF12
M16	2.0	24	16.0	HNF16.Q1
M20	2.5	30	20.0	HNF20.Q1

Dimensions are nominal to DIN 6923 with a serrated bearing face. Class 8 steel, Bright Zinc Plated. The '.Q1' suffix denotes the website pack/price variant code. Verify dimensions before use.

TYPICAL APPLICATIONS

Structural steelwork and bolted connections	HVAC and mechanical services
Strut, channel and bracketry assemblies	General fabrication and maintenance
Plant, machinery and equipment mounting	Construction, agricultural and automotive

To Order: Visit directchannel.uk.com or call **0121 270 8507** | Trade & bulk enquiries: sales@directchannel.uk.com | Most orders dispatched same or next working day.

DISCLAIMER & LEGAL NOTICE

Direct Channel Support Systems Ltd has made every reasonable effort to ensure the accuracy and completeness of the information contained in this datasheet. All product specifications, dimensions, and technical details are provided for guidance purposes only. Direct Channel Support Systems Ltd reserves the right to alter, update, or withdraw any product or specification at any time and without prior notice. To the fullest extent permitted by law, Direct Channel Support Systems Ltd accepts no liability for any loss, damage, or consequential loss arising from reliance on the information contained herein. Customers are advised to verify all specifications prior to ordering. For the most current product information visit directchannel.uk.com or contact our sales team.