

# Premier Kwik Grip Double-Sided Pipe Clamp

Double-Fix Split-Ring Clamp | Bright Zinc Plated Steel | Rubber-Lined Anti-Vibration | Dual M8 / M10 Thread | 9 – 254 mm

Direct Channel Premier Kwik Grip Double-Sided Rubber-Lined Pipe Clamps provide secure, vibration-dampening pipe support with a fixing point on each side of the clamp. The double-fix design allows mounting from either side or back-to-back, making it ideal for twin pipe runs and trapeze arrangements across HVAC, plumbing, mechanical and electrical installations.

Each clamp is formed from a ribbed steel band with a Bright Zinc Plated (BZP) finish and is lined with anti-vibration rubber for quiet, protected support. Supplied complete with fixing bolts, plastic washers and dual-threaded connection nuts that accept both M8 and M10 studding. Suitable for PVC, PE, PP, cast iron, steel and copper pipe, and sold individually.

## SPECIFICATION

<b>Product Type</b>	Double-fix (double-sided) split-ring pipe clamp
<b>Material</b>	Ribbed steel band
<b>Finish</b>	Bright Zinc Plated (BZP)
<b>Rubber Lining</b>	TPE, 55 ± 5 Shore A (EPDM available on request)
<b>Connection Nut</b>	Dual thread — M8 / M10, fixing point each side
<b>Closure</b>	Two-piece split ring + fixing bolts and plastic washers
<b>Clamping Range</b>	9 mm – 254 mm (across the range)
<b>Working / Breaking Load</b>	1.0 – 3.2 kN working / 2.0 – 10.0 kN breaking (size dependent)
<b>Temperature Range</b>	-50°C to +110°C
<b>Use</b>	Internal & external — anti-vibration / sound reduction
<b>Compatibility</b>	PVC, PE, PP, cast iron, steel and copper pipe
<b>Supply</b>	Sold individually

## KEY FEATURES

<ul style="list-style-type: none"> <li>• Rubber-lined for anti-vibration and sound reduction</li> <li>• Double-sided fixing — a connection point on each side</li> <li>• Bright Zinc Plated (BZP) ribbed steel band</li> <li>• 22 clamping ranges from 9 mm to 254 mm</li> </ul>	<ul style="list-style-type: none"> <li>• Supplied with fixing bolts and plastic washers</li> <li>• Suits back-to-back, twin-run and trapeze mounting</li> <li>• Dual-thread nut — takes both M8 and M10</li> <li>• Suits PVC, PE, PP, cast iron, steel &amp; copper pipe</li> </ul>
--	---

## TECHNICAL DRAWING

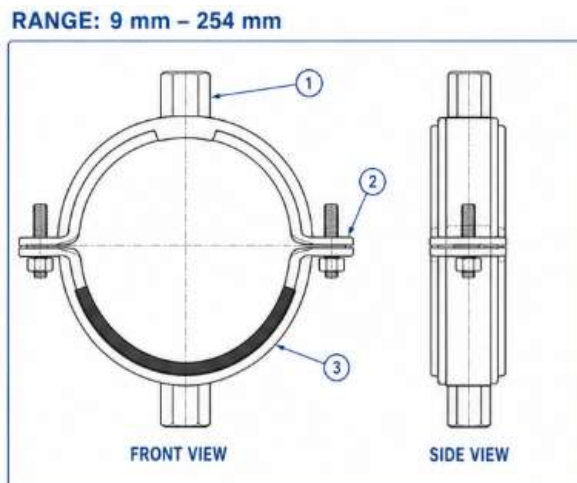

## AVAILABLE SIZES

Code	Clamping Range (mm)	Recommended Load (kN)	Breaking Load (kN)	Thread	Finish
DKP0912	9 – 12	1.0	2.0	M8 / M10	BZP
DKP1320	13 – 20	1.3	3.9	M8 / M10	BZP
DKP1519	15 – 19	1.3	3.9	M8 / M10	BZP
DKP2025	20 – 25	1.3	3.9	M8 / M10	BZP
DKP2530	25 – 30	1.3	3.9	M8 / M10	BZP
DKP3237	32 – 37	1.3	3.9	M8 / M10	BZP
DKP3844	38 – 44	2.3	4.8	M8 / M10	BZP
DKP4853	48 – 53	2.3	4.8	M8 / M10	BZP
DKP5359	53 – 59	2.3	4.8	M8 / M10	BZP
DKP5965	59 – 65	2.3	4.8	M8 / M10	BZP
DKP6777	67 – 77	2.6	6.9	M8 / M10	BZP
DKP7480	74 – 80	2.6	6.9	M8 / M10	BZP
DKP8393	83 – 93	2.6	6.9	M8 / M10	BZP
DKP95103	95 – 103	2.6	6.9	M8 / M10	BZP
DKP108118	108 – 118	3.2	6.9	M8 / M10	BZP
DKP121127	121 – 127	3.2	7.8	M8 / M10	BZP
DKP133143	133 – 143	3.2	7.8	M8 / M10	BZP
DKP159169	159 – 169	3.2	8.0	M8 / M10	BZP
DKP198202	198 – 202	3.2	10.0	M8 / M10	BZP
DKP210215	210 – 215	3.2	10.0	M8 / M10	BZP
DKP216225	216 – 225	3.2	10.0	M8 / M10	BZP
DKP249254	249 – 254	–	–	M8 / M10	BZP

Working and breaking loads are the rated guidance values in kN for the clamp size/band, matched by clamping range. The double-fix uses the same band as the equivalent single-fix clamp, with a fixing point on each side, so these are taken as a conservative rating; apply an appropriate factor of safety and confirm the double-fix configuration with our sales team. The 249–254 mm size is beyond the rated table — loads on request. Finish: Bright Zinc Plated (BZP).

## TYPICAL APPLICATIONS

HVAC and mechanical services pipework	Electrical conduit and containment support
Plumbing and sanitary pipe runs	Copper, steel and plastic pipe installations
Anti-vibration support for pumps and risers	Commercial, industrial and residential projects

**To Order:** Visit [directchannel.uk.com](https://directchannel.uk.com) or call **0121 270 8507** | Trade & bulk enquiries: [sales@directchannel.uk.com](mailto:sales@directchannel.uk.com) | Most orders dispatched same or next working day.

### DISCLAIMER & LEGAL NOTICE

Direct Channel Support Systems Ltd has made every reasonable effort to ensure the accuracy and completeness of the information contained in this datasheet. All product specifications, dimensions, and technical details are provided for guidance purposes only. Direct Channel Support Systems Ltd reserves the right to alter, update, or withdraw any product or specification at any time and without prior notice. To the fullest extent permitted by law, Direct Channel Support Systems Ltd accepts no liability for any loss, damage, or consequential loss arising from reliance on the information contained herein. Customers are advised to verify all specifications prior to ordering. For the most current product information visit [directchannel.uk.com](https://directchannel.uk.com) or contact our sales team.