

Back to Back Strut Channel — Hot Dip Galvanised (HDG)

Plain & Slotted | 2.5mm Heavy Duty | 82x41mm | Spot Welded | For External Use | BS6946:1988

Direct Channel Hot Dip Galvanised (HDG) Back to Back Strut Channel is constructed from two 41x41mm HDG channels spot welded together at the web to form a 82x41mm box-section profile. The HDG finish provides a thick, robust zinc coating for excellent corrosion resistance, making this profile ideal for external, exposed, and corrosive environments where enhanced durability is required alongside increased structural capacity.

Available in plain and slotted configurations across standard stock lengths of 1m to 6m. Compatible with all P1001-type channel nuts and accessories.

SPECIFICATION	
Profile	82 × 41mm (2 × 41×41mm spot welded back to back)
Material	Mild Steel
Finish	Hot Dip Galvanised (HDG)
Standard	BS6946:1988
Thickness	2.5mm (per channel)
Overall Height	81.2 – 82.8mm
Width	40.9 – 41.7mm
Return Lip	6.5 – 7.5mm (per channel)
Slot Width	13.5 – 14.5mm (slotted variants)
Slot Length	27.5 – 28.5mm (slotted variants)
Construction	Spot welded at the web
Stock Lengths	1m, 2m, 3m, 4m, 5m, 6m
Application	External use — suitable for outdoor and exposed environments

Construction Note: Channels are joined back to back using spot welding at the web. The two 41x41mm channels are welded together to form an 82x41mm box-section profile, providing significantly increased load capacity and torsional rigidity compared to a single channel.

KEY FEATURES

- 82x41mm profile — two 41x41mm channels spot welded at the web
- Significantly higher load capacity than single channel
- Plain and slotted variants — 1m to 6m stock lengths
- 2.5mm heavy duty steel throughout
- Hot Dip Galvanised (HDG) — thick zinc coating for external use
- BS6946:1988 — suitable for outdoor and exposed environments
- Stock lengths: 1m, 2m, 3m, 4m, 5m, 6m
- Compatible with all P1001-type channel nuts and accessories

TECHNICAL DRAWING

1. CROSS SECTION (BACK TO BACK – VERTICAL)

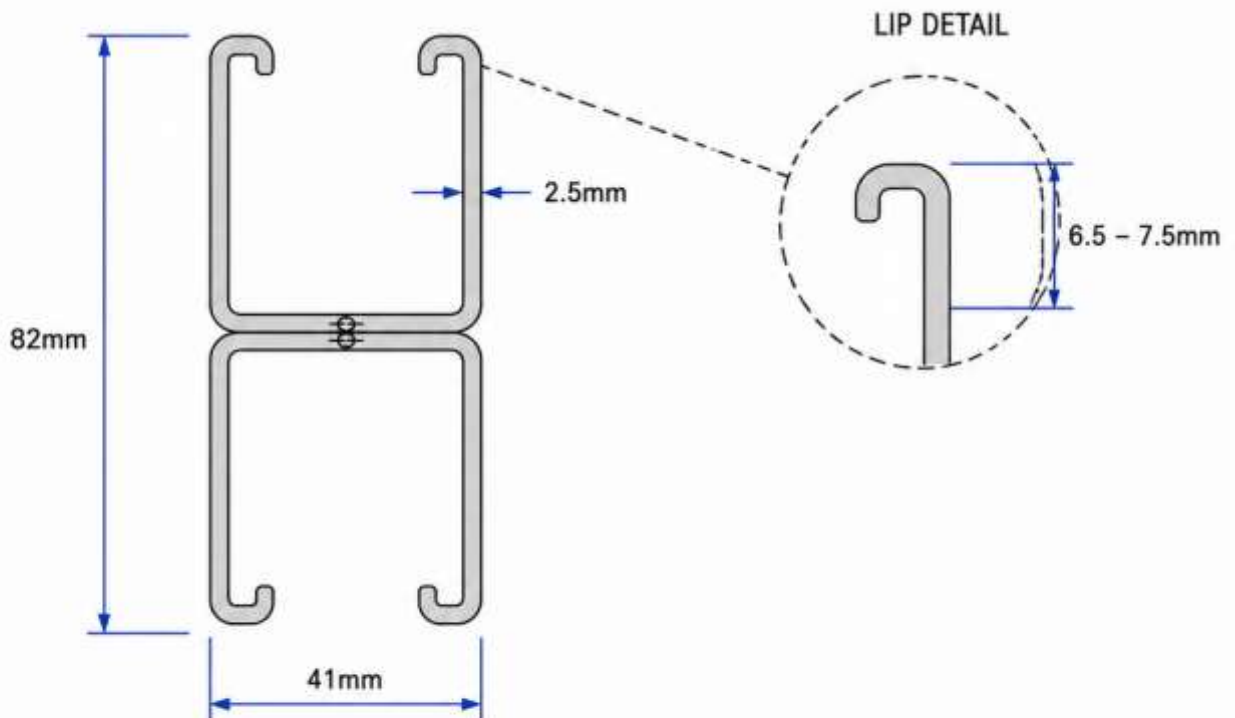

Note: Channels are joined back to back using spot welding at the web.

2. SLOT DETAIL – REFERENCE FOR SLOTTED CHANNELS

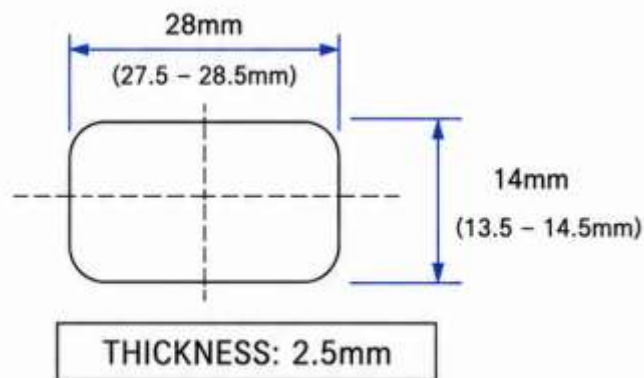

Note: Slots dimensions are for reference for slotted channels.

AVAILABLE SIZES — FULL PRODUCT RANGE

SKU / Part No.	Length	Profile	Type	Thickness	Description
Plain — Back to Back					
CP41HB-1	1m	82×41mm	Plain	2.5mm	82×41mm HDG Back to Back Plain Channel — 1 Metre
CP41HB-2	2m	82×41mm	Plain	2.5mm	82×41mm HDG Back to Back Plain Channel — 2 Metre
CP41HB	3m	82×41mm	Plain	2.5mm	82×41mm HDG Back to Back Plain Channel — 3 Metre
CP41HB-4	4m	82×41mm	Plain	2.5mm	82×41mm HDG Back to Back Plain Channel — 4 Metre
CP41HB-5	5m	82×41mm	Plain	2.5mm	82×41mm HDG Back to Back Plain Channel — 5 Metre
CP41HB-6	6m	82×41mm	Plain	2.5mm	82×41mm HDG Back to Back Plain Channel — 6 Metre
Slotted — Back to Back					
CS41HB-1	1m	82×41mm	Slotted	2.5mm	82×41mm HDG Back to Back Slotted Channel — 1 Metre
CS41HB-2	2m	82×41mm	Slotted	2.5mm	82×41mm HDG Back to Back Slotted Channel — 2 Metre
CS41HB	3m	82×41mm	Slotted	2.5mm	82×41mm HDG Back to Back Slotted Channel — 3 Metre
CS41HB-4	4m	82×41mm	Slotted	2.5mm	82×41mm HDG Back to Back Slotted Channel — 4 Metre
CS41HB-5	5m	82×41mm	Slotted	2.5mm	82×41mm HDG Back to Back Slotted Channel — 5 Metre
CS41HB-6	6m	82×41mm	Slotted	2.5mm	82×41mm HDG Back to Back Slotted Channel — 6 Metre

TYPICAL APPLICATIONS

Heavy duty mechanical and electrical (M&E) support frameworks High load cable containment tray and ladder rack support structures Structural column and post applications in building services	Industrial racking, shelving, and heavy structural frameworks Plant room and equipment support requiring enhanced rigidity Compatible with all P1001-type channel nuts and accessories
--	--

To Order: Visit directchannel.uk.com or call **0121 270 8507** | Trade & bulk enquiries: sales@directchannel.uk.com | Most orders dispatched same or next working day.

DISCLAIMER & LEGAL NOTICE
 Direct Channel Support Systems Ltd has made every reasonable effort to ensure the accuracy and completeness of the information contained in this datasheet. All product specifications, dimensions, and technical details are provided for guidance purposes only. Direct Channel Support Systems Ltd reserves the right to alter, update, or withdraw any product or specification at any time and without prior notice. To the fullest extent permitted by law, Direct Channel Support Systems Ltd accepts no liability for any loss, damage, or consequential loss arising from reliance on the information contained herein. Customers are advised to verify all specifications prior to ordering. For the most current product information visit directchannel.uk.com or contact our sales team.